

An *M3* Maglev System for Old Dominion University

No. 78

Richard Thornton, Tracy Clark, Brian Perreault, Jim Wieler, Steve Levine

MagneMotion Inc., 20 Sudbury Road, Acton, MA 01742, USA

rthornton@magnemotion.com.

ABSTRACT: The *M3* Maglev System was originally developed as part of the U.S. Urban Maglev Project. Development is now focused on demonstrating operation on an existing guideway at Old Dominion University in Norfolk, Virginia. The design is based on the use of permanent magnets for ElectroMagnetic Suspension and guidance and a Linear Synchronous Motor for propulsion. This paper describes the Urban Maglev Project and the *M3* System, and describes how the system can be adopted for ODU and for other similar applications.

1 INTRODUCTION

This paper describes the *M3* maglev system, how it will be deployed at Old Dominion University, and the potential of systems like this to be used in a variety of urban applications.

2 THE U.S. URBAN MAGLEV PROJECT

On January 29, 1999, the U.S. Federal Transit Administration announced the Urban Maglev Project (UMP) with a vision to “Develop American magnetic levitation technology to improve urban mass transportation.” The Technical Objectives were to:

1. Develop a base of knowledge about Urban Maglev low speed technology supportive of eventual deployment, including a full system design and advanced technology hardware development and demonstration.
2. Enhance one or more of critical maglev subsystems using advanced technologies for levitation, propulsion, power supply and delivery, communication and control, guideway design, vehicle design, and other critical vehicle and guideway subsystems.

In the course of the UMP, design specifications were developed and some of these are given in Table 1, which is taken from [9].

Table 1. FTA Urban Maglev specifications.

Parameter	Metric	English
Speed, max	44.7 m/s	100 mph
System capacity, min	12,000 pphpd	
Acceleration, max	1.6 m/s ²	3.6 mph/s
Jerk, max	2.5 m/s ³	5.6 mph/s ²
Braking, emergency	3.6 m/s ²	8.1 mph/s
Horizontal turn radius, min	25 m	60 ft
Vertical turn radius, min	1000 m	984 ft
Grade, max	10 %	
DC magnetic field in vehicle	0.5 mT	5 Gauss
AC magnetic field in vehicle	0.1 mT	1 Gauss
LSM efficiency, min	80 %	
Availability, min	99.99 %	
Wind limit for full operation	14 m/s	31 mph
Ride quality, min	ISO 1997	
Noise level inside, max	70 dBA	

pphpd is passengers per hour per direction

The UMP supported five teams, one of which was a MagneMotion-based group that developed the *M3* Maglev System. This project included the construction of a reduced length model that demonstrated operation over a short guideway and simulation of many aspects of a full scale design. The Urban Maglev Project culminated in an FTA Maglev Workshop in Washington, DC in September, 2005 [1]. In 2008, the UMP was restarted with support for two designs, one of which is the *M3* maglev system.

The FTA is now providing cost sharing support for MagneMotion and Old Dominion University to demonstrate operation of the *M3* System on an existing guideway at ODU in Norfolk, Virginia. Figure 1 shows a photograph of a section of the ODU guideway.



Fig. 1. Section of existing maglev guideway at ODU.

The ODU project will demonstrate operation of “sleds” that have the characteristics of vehicles and will operate on a 162 meter section of the existing guideway at speeds up to 25 m/s (56 mph, 90 km/h). This ODU Project also includes work by ODU on dynamic analysis, ride quality, and ridership. The next ODU Project is to create an operating maglev system and MagneMotion has a longer term objective of applying this design for other applications.

3 THE *M3* MAGLEV SYSTEM

The *M3* was designed from a system perspective with a focus on being competitive with existing and planned Automated People Movers (APM), and conventional transit systems including heavy rail, light rail, and commuter rail. MagneMotion created a baseline design that meets the FTA specifications and much more.

The design objectives were:

- Minimize cost by reducing vehicle weight and complexity, matching the guideway to the vehicle and environment, reducing energy consumption, and reducing the vehicle capacity required for a given passenger throughput.
- Minimize trip time by increasing average speed, increasing acceleration rate, decreasing vehicle headway, reducing station spacing, and using station skipping control.
- Minimize environmental impact by using a guideway with reduced size, reducing audible noise, minimizing energy consumption, and improving ride quality.

- Improve reliability by eliminating the use of wheels, eliminating the use of mechanical brakes except for emergency, using redundant motors and suspension controllers, using distributed control, reducing the number of moving parts and components that have limited lifetime, eliminating power collection with sliding contacts, and using semiconductor power components below their rating.
- Minimize risk by using a dedicated guideway with exclusive right-of-way, using automatic control to minimize accidents caused by human error, using a suspension system that cannot derail, using a control system that is not dependent on communication with a moving vehicle, and using propulsion and braking that do not depend on wheel traction.
- Use state-of-the-art but proven technology by using high performance microprocessors and power electronics with emphasis on reliability, using modern control algorithms with emphasis on safety and throughput, using high energy neodymium-iron-boron magnets, using available computer aided design tools to model all critical aspects of the design, and using detailed simulation to predict effects of normal and abnormal behavior.

In order to meet these objectives, the *M3* design is based on five key features:

- Permanent magnets for ElectroMagnetic Suspension (EMS)
- Small vehicles and lightweight guideways
- High efficiency Linear Synchronous Motor (LSM) propulsion
- Guideway based control
- Focus on safety and reliability

3.1 *Permanent magnet suspension*

The permanent magnets on the vehicle are organized into pods such as the one shown in Figure 2 that was used in the initial prototype. Figure 3 shows how the pods are combined into a bogie that will be used in the ODU Project.

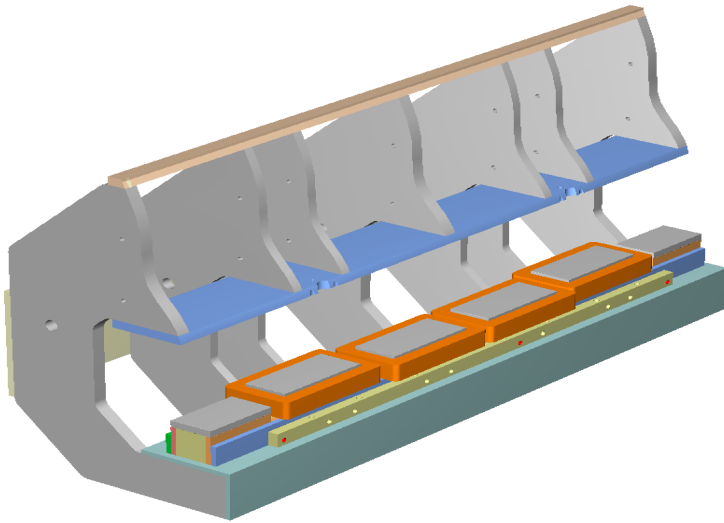

Fig. 2. Magnet pod with permanent magnets and control coils.

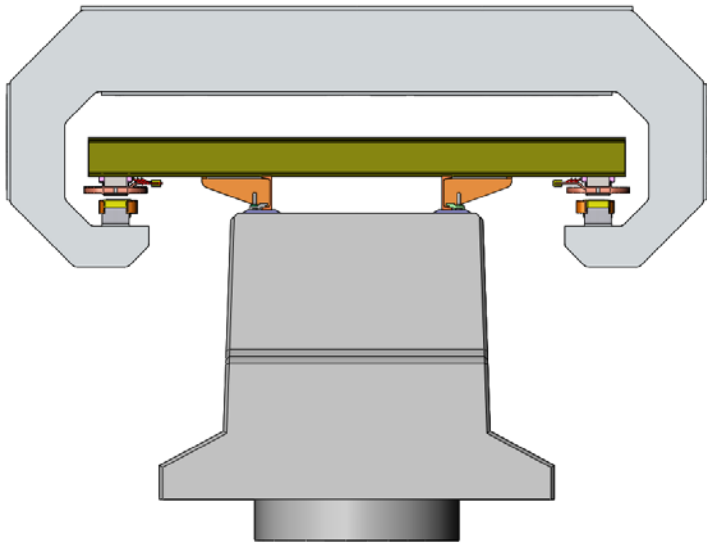

Fig. 3. Bogie and LSM stators mounted on ODU girder.

The permanent magnets provide most of the suspension and guidance forces. Coils wound around the magnets are excited so as to stabilize the suspension and control the magnetic gap. Passive lateral guidance occurs as a natural byproduct of the suspension force and lateral offsets in the magnets allow the same coils that stabilize the suspension to also provide damping of lateral motion. The same magnetic field that produces the suspension and guidance forces also interacts with current in the guideway to produce propulsive force.

The use of one set of permanent magnets for EMS, guidance and propulsion is unique to *M3*. All other demonstrated EMS designs use electromagnets instead of permanent magnets and more than one set of magnets for suspension, guidance and propulsion. Two examples: Transrapid uses one set of electromagnets for suspension and the field for LSM propulsion, a separate steel rail on the guideway, and coils on the vehicles to provide guidance. HSST uses

one set of electromagnets for suspension and guidance and another set for Linear Induction Motor propulsion. The use of permanent magnets in *M3* allows doubling the magnetic gap and more than an order of magnitude reduction in onboard power requirements for suspension. The use of only one set of magnets means there is only one magnetic gap to control so guideways, vehicle weight, and cost are lower.

3.2 Small vehicles and lightweight guideways

The use of small vehicles operating with short headway has many advantages such as operational flexibility and lighter guideway girders because there is only one vehicle on a girder and the spacing between vehicles ensures that beam oscillations produced by one vehicle do not impact the following vehicle. Girder stiffness is chosen to achieve good ride quality when a vehicle travels over it, so reducing vehicle mass allows reduction in girder size and cost, which dominates total system cost. For practical designs the girder strength is sufficient to support several vehicles.

Figure 4 shows a rendition of a proposed ODU vehicle on the existing guideway. The vehicle has four magnet pods, two per bogie, with one bogie at each end of the vehicle. For guideways with short horizontal or vertical turns, the bogies rotate and tilt with respect to the vehicle body in order for the vehicle to meet the horizontal and vertical turn radii requirements in Table 1. A secondary suspension can be used to improve ride quality at high speeds but is not expected to be needed at ODU. This vehicle and propulsion system can meet all of the requirements given in Table 1.

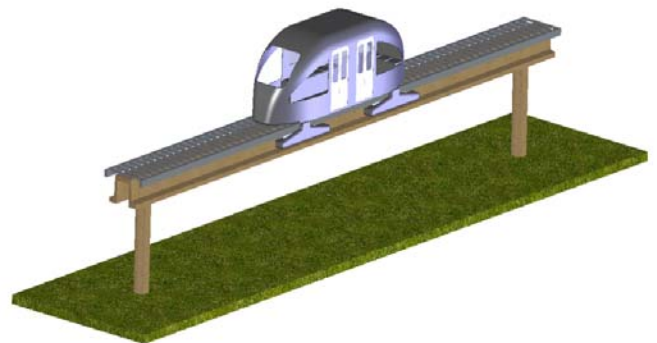

Fig. 4. Vehicle concept for *M3* System with ODU girders.

3.3 LSM propulsion

The vehicles are propelled by two long stator LSMs, one on either side. This type of motor requires that the guideway be divided into blocks with no more than one vehicle in a block. LSM cost is dominated by the cost of the stators so we intend to use the smallest stators consistent with acceptable temperature rise of the windings and good motor efficiency. In order to increase efficiency we intend to decrease block size, but of a separate inverter for each block would increase cost if the block length is small. The most cost effective design is to divide the blocks into sub-blocks that are relatively short and only excited when they contribute to propulsion. An inverter can be switched to excite a specific sub-block using switches that are substantially less expensive than inverters.

3.4 Safety and reliability

A key requirement of any APM is the need for a very high level of safety and reliability under all conceivable conditions. For example, we can expect occasional loss of power, failure of vehicle suspension system components, problems created by human actions, and the impact of sudden and severe weather. Achieving high reliability is an important part of achieving safe operation. Following are some of the features that increase safety and reliability.

- The safety-critical part of the propulsion control system is on the wayside and does not depend on communication with the vehicle. Facilities will be provided for communicating with passengers, but the guideway-based motor controllers know precisely where every vehicle is at all times. The high level controllers monitor the motor controllers for potential failures.
- There are no wheels, rotary motor bearings or gears that require frequent and expensive maintenance.
- There are two LSMs, port and starboard, and if one fails the other can provide adequate propulsion to move a vehicle to the nearest station.
- The suspension controllers on the vehicle are redundant with more than one controller for each pod. Failure of one controller will not cause the vehicle to touch the guideway because the permanent magnets still provide force and the stability of the suspension can be maintained by the operative controllers.
- All electronic controllers have battery backup on their power supplies so that the control does not fail if the power fails. The vehicle can then be

magnetically braked without resorting to emergency braking. With a modest amount of emergency generator capability all vehicles can be moved to a station.

- There is no need to transfer propulsion power to the vehicle so maintenance of a catenary or third rail power system is not required. Power for onboard HVAC, communication and control is modest and can be provided by a non-contacting inductive power transfer system that is operative at all speeds.
- The vehicle is captive to the guideway and can not derail. Unless the guideway is destroyed by an external force, the worst case result from component failure is for a vehicle to skid to a stop on skid rails that are part of the guideway. This type of emergency stopping has been successfully demonstrated on the Transrapid Maglev Systems.
- By using a monorail-like design with dedicated right-of-way most non-passenger injuries and fatalities can be avoided.
- Mechanical brakes that press on the guideway to provide emergency braking, but they will be used only in emergency or when the vehicle is stopped, so they only require regular testing to insure proper operation.

Once the *M3* system has been fully developed and subjected to extensive testing there is every reason to expect that it will operate as designed and be more reliable and safer than any existing wheel-based transit system.

4 APPLYING *M3* AT ODU

The *M3* design is for a basic suspension and propulsion technology and, like the use of steel wheels on steel rails, can be used with a wide range of vehicle types, guideway structures and control strategies. The baseline design was for competing with conventional urban transit, but the technology is good for a wide variety of trip lengths and maximum speeds. This section discusses the answer to a number of application questions with a focus on lower speed applications.

- What should be the design speed and acceleration?
- What size vehicle should be used?
- What is the best block layout?
- How do you balance reducing cost and increasing efficiency?
- How do you control the vehicles for high capacity and safe operation?

4.1 Choice of maximum speed

With maglev and LSM propulsion there are significant advantages of using higher top speeds than are used with other propulsion means. The higher speed means fewer and smaller vehicles can provide a given capacity. The cost disadvantage of higher speeds is surprisingly small compared to the benefits. Higher speed and acceleration lead to reduced travel time and this is an important factor in increasing user acceptance of public transportation. This section discusses factors that affect the choice of maximum speed.

Figure 5 shows contours of constant travel time in the distance-speed plane assuming the baseline acceleration and jerk limits, 1.6 m/s^2 and 1 m/s^3 . It also shows the boundary of the region where no vehicle reaches maximum speed; there is no point in designing for a maximum speed above or near this boundary given approximately by $v = (d a_{\max})^{1/2}$.

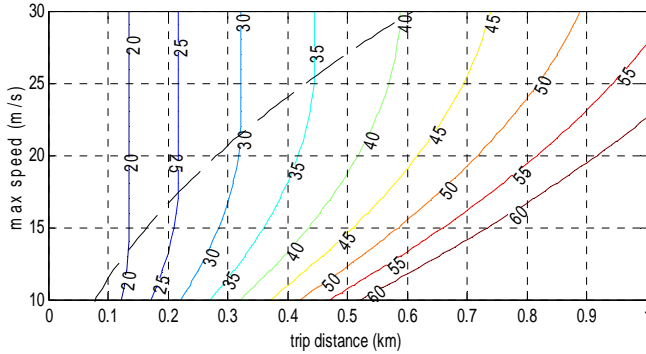

Fig. 5. Contours of constant travel time (seconds) for $a_{\max} = 1.6 \text{ m/s}^2$, $j_{\max} = 1.0 \text{ m/s}^3$.

It is seldom desirable to design for maximum acceleration up to maximum speed. A long stator LSM has significant winding inductance and if we limit the power when operating near the maximum speed we can reduce the required inverter kVA rating. Also, at the higher speeds the aerodynamic drag becomes important so reduced acceleration at high speed makes it less costly to increase maximum speed. Fortunately, a substantial limit on acceleration power does not have a major effect on travel time. Figure 6 shows the acceleration, velocity and distance plots vs. time for a trip of 1 km with a maximum speed of 25 m/s and constant power for acceleration for speeds greater than 15 m/s. The reduction in peak power is substantial but the travel time, as compared with the time shown in Fig. 5, only increases from 57.2 to 57.8 seconds. In future examples we assume that for speeds above 60% of maximum speed the acceleration power is limited.

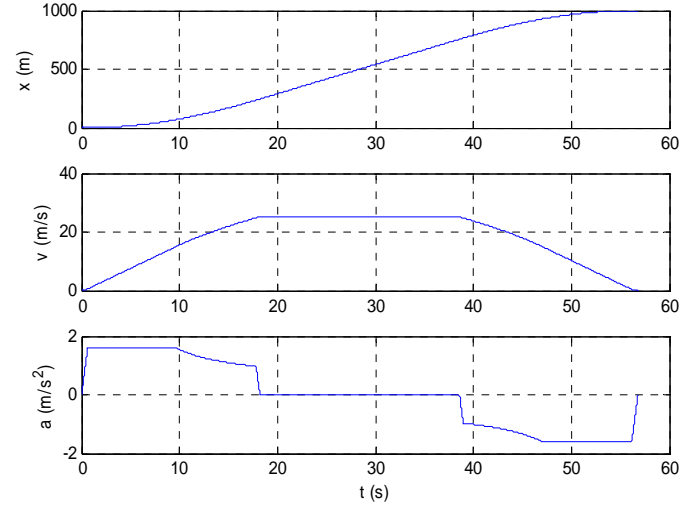

Fig. 6. Distance, speed and acceleration for a 1 km trip with a maximum speed of 25 m/s.

In addition to travel time there are stopped times associated with opening and closing doors and passengers leaving and entering the vehicle. For a typical stop, and assuming a small vehicle with enough fast acting doors, the stopped time can be held to an average of 20 seconds per stop, a value typical of buses but less than most Automated People Mover (APM) vehicles. For a transit system with a top speed of 25 m/s and a 20 second stop every 1 km the average travel speed is 12.8 m/s (29 mph, 46 km/h). This is twice the average speed of most transit systems when operating with this short station spacing. The reduced headway means passengers do not need to wait very long for a vehicle and this decreases average trip time even further.

The common metric for rating a transit system is passengers per hour per direction, but this is only part of the story. Vibhuti has proposed that a better measure is to multiply maximum speed by capacity to recognize the importance of speed to the customer. This metric is “pkmphph” and is a good suggestion, but does not recognize that travel time depends on how many stops are made, how long a stop lasts, acceleration rates, etc. A better metric is the product of average speed times capacity, where average speed means the total distance divided by total time, including the average time a rider must wait for a vehicle. With this metric the M3 Maglev System ranks very high because of the high capacity coupled with high average travel speed and short wait time.

4.2 Vehicle design

A baseline vehicle is described in Table 2 and depicted in Figure 4. This vehicle is constructed from

composite material so as to reduce mass and allow a streamlined shape.

Table 2. Baseline vehicle specifications.

Parameter	Metric	English
Empty vehicle mass	5.5 Mg	6 tons
Maximum load (36 pass. x 83.3 kg)	3 Mg	3.3 tons
Magnetic gap with 50% load	20 mm	0.79 in
Variation in gap, full load to no load	6.5 mm	0.26 in
Vehicle length	10 m	32.8 ft
Vehicle width	2.75 m	9.02 ft
Vehicle height, overall	4 m	13.1 ft
Suspension gage, center-to-center	2 m	6.56 ft
Suspension rail width	80 mm	3.15 in
Maximum lateral force, 20 mm gap	26 kN	5850 lbs
Maximum LSM accelerating force	16 kN	3600 lbs
Maximum LSM decelerating force	20 kN	4500 lbs
Aerodynamic drag @ 25 m/s	1.2 kN	270 lbs

4.3 Blocks and sub-blocks

For maximum efficiency we would like to excite only that portion of the winding that produces propulsive force. The “Locally Commutated LSM” has been proposed as a solution to this problem [8]. The idea is to have a separate electronic power module for exciting a small number of coils and only excite the coils when there is a magnet near it. MagneMotion has used this approach in small motors where electronic cost is not too high, but it becomes prohibitively expensive when each coil requires many kilowatts of power.

The most cost effective solution is to excite a “sub-block” which is typically less than three times the length of a vehicle. For LSM powered vehicles climbing very steep grades with heavy loads, the sub-block length could be a fraction of a vehicle length but for most people-carrying vehicles the best choice is usually 1.2 to three times the vehicle length. For the baseline 10 meter long vehicle operating on an 80’ (24.4 m) ODU guideway girder, an appropriate sub-block length is 12 or 24 meters. The sub-block length does not have to be constant and can be tailored to the force, speed and headway requirements in each region of the guideway.

Each sub-block has a 3-phase electronic switch mounted in close proximity to the stator and 3-phase cables deliver power from inverters to all of the sub-blocks in a block. Guideway based position sensing information is fed to the motor controllers so they know where the vehicle is and what switch to close. For best results two inverters are used for each block with one inverter driving the odd number blocks and the other driving the even number blocks. At any given time the vehicle is being propelled by one or both inverters for each LSM. All of the inverters are

supplied from a DC bus so that regenerated power from one inverter can be used as input power for another inverter driving a different vehicle.

Using today’s technology for *M3* vehicles the most cost effective inverters use IGBT switches to control the excitation current waveform and use thyristors for sub-block switching. Currently an inverter, including a microprocessor based motor controller, costs about 10 times as much as a switch, but this ratio could change as technology changes.

The minimum block length is dictated by vehicle headway requirements. For the one kilometer trip in Figure 6 a typical design will use 10 blocks for vehicles operating with eight second headway. With longer headway the number of blocks can be reduced.

Although there can only be one moving vehicle in a block, with sub-block switching there can be one or more stationary vehicles in a block. This feature allows longer blocks in and near stations and in vehicle storage areas.

4.4 Energy efficiency

Energy efficiency is an important design parameter and, within limits, we can increase efficiency and thereby reduce operating cost at the expense of capital cost.

Figure 7 shows the input and output power for the trip whose performance is shown in Figure 6. This simulation is for the LSM stator designed for use at ODU, which has a mass of 42 kg/m per LSM. A heavier stator would allow higher efficiency but cost is roughly proportional to mass and the ODU design was deemed a good compromise. The sub-block length is assumed to be 12 meters and the vehicle is assumed to have a 50% load, or 18 passengers, and a total mass of seven Mg. The peak power demand is 272 kW and if regenerative braking is not used the energy input increases by 27%.

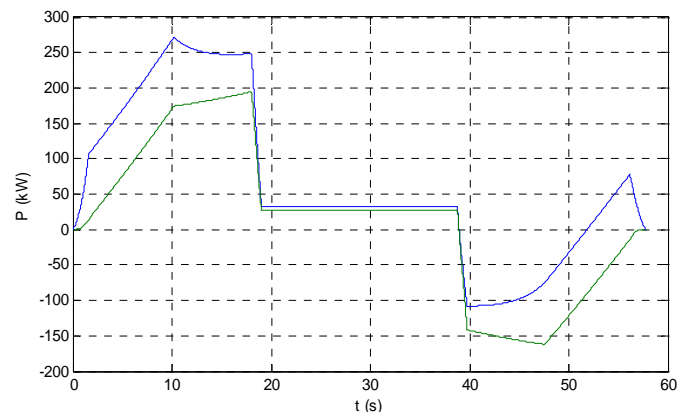

Fig. 7. Electrical power input and mechanical power output for the trip of Figure 4.

Figure 7 shows how inverter rating is reduced by limiting peak power when operating near maximum speed; the peak would be 46% higher without this limit. When the inverter is braking the vehicle it is possible to brake faster at higher speeds, but the time savings are minimal. This ability to brake faster is most useful for rapid braking under emergency conditions since it can reduce the stopping distance by a substantial amount. With the emergency braking rate given in Table 1, 3.6 m/s^2 , the vehicle can stop in seven seconds while traveling only 87 meters. This means that with emergency braking and eight second headway the vehicle can always stop in the clear distance ahead, the “Brick Wall” criterion.

The long stator LSM has the reputation of being inefficient due to the large magnetic gap and because portions of the winding do not contribute to propulsion. Some installations have demonstrated poor efficiency, but with careful design the energy consumption can be substantially less than for conventional rotary motor propulsion. There are several reasons for this:

- For urban transportation most of the energy usage is for acceleration. With the propulsion on the guideway the vehicle is much lighter so less energy is used.
- Figure 5 shows that the efficiency is low at low speeds and high thrust but reaches 86% under cruise conditions. While rotary transit motors may average a little higher efficiency, they expend energy in electronic controllers, gears, wheel friction, etc. so that the effective motor efficiency is about the same as for *M3*.
- With small vehicles it is easier to adapt the vehicles to demand so that less energy is wasted propelling long trains with few passengers during off-peak times. Operating clusters of vehicles with station skipping control provides even more energy savings.
- The *M3* design envisions closely spaced vehicles so that regenerated energy can be readily reused by other vehicles. While it is possible to regenerate energy into the power grid, this is generally not feasible because of the high peak power levels required for conventional transit with heavy trains.

Table 3 gives efficiency predictions of the LSM for different cruise speeds with the assumption that the trip is long enough to reach maximum speed. The motor efficiency while cruising is in the 83% to 87%

range, which is high by conventional transit standards.

Table 3. Efficiency of baseline design with 12 meter sub-blocks.

Parameter \ Speed, m/s	20	25	30
Speed, mph	45	56	67
Speed, km/h	72	90	108
Time to accelerate or brake, s	15	19	22
Distance to accelerate or brake, m	162	252	358
Peak power input, kW	233	272	313
Motor efficiency accelerating %	57	62	66
Motor efficiency cruising, %	83	86	87
Generator efficiency braking, %	23	38	48

Figure 8 compares the specific energy consumption for an *M3* system with other modes. The simulation assumes a baseline vehicle carrying a 50% load of 18 passengers and accounts for losses due to aerodynamic drag, winding resistance, eddy current and hysteresis in laminations, inverters, cables and rectifiers. In order to account for HVAC and other power consumption, the loss computed by simulation was increased by 50%.

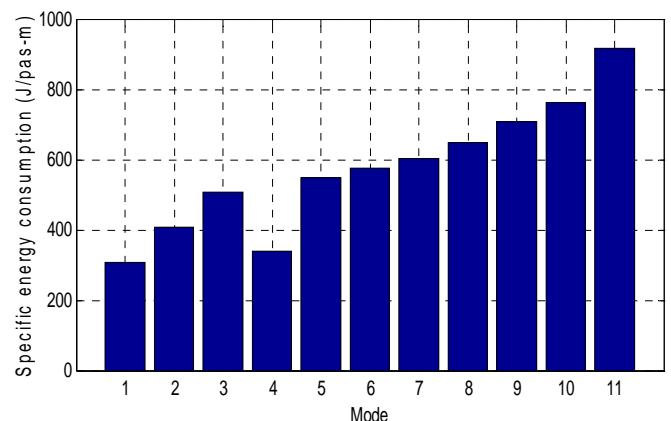

Specific energy use in J/pas-m for different Modes:

1. *M3*, max speed = 25 m/s, travel distance = 1 km
2. *M3*, max speed = 20 m/s, travel distance = 0.5 km
3. *M3*, max speed = 25 m/s, travel distance = 0.5 km.
4. Passenger car-of-the-future, 50 mpg, 1.57 pas
5. Ultra PRT, max speed = 11 m/s
6. Amtrak intercity rail
7. Rail transit
8. Commuter rail
9. Commercial domestic aviation
10. Passenger car in 2006 excluding SUV & minivans, 22.4 mpg, 1.57 pas
11. Transit motor bus

Fig. 8. Energy consumption for different modes.

Energy consumption data for other modes is for 2006 and taken from [3], Table 2.12. Published energy consumption is expressed in BTUs and to convert to an equivalent electric energy it is assumed that electric generation and distribution efficiency is 33% [3]. Thus 1 BTU of thermal energy is equivalent to

348 Joules of electric energy and 1 J/pas-m is equivalent to 4.62 BTU/pas-mile. Ultra PRT energy usage is from their web site. For typical trip speed profiles the specific energy consumption for *M3* is significantly less than for conventional transit. Note that the car-of-the-future has much lower specific energy consumption than any existing public transportation technology, and this is the benchmark against which new technology should be compared.

These examples make it clear why it is desirable to use small light vehicles with dynamic scheduling that matches capacity to demand and station skipping strategies to minimize the number of stops. When it is necessary to stop frequently there can be significant savings in energy by using regenerative braking and reducing maximum speed when capacity requirements are not high. If these strategies are used the energy consumption by *M3* can rival the car-of-the-future.

4.5 Control

The control system consists of motor controllers for each inverter and higher level controllers to coordinate vehicle movement. *M3* is based on the use of small vehicles operating with short headway. In order to ensure safe operation the vehicles are organized into clusters with intra-cluster vehicle headway based on "Safe Follower" control. This control scheme [4] requires that a fully loaded vehicle be able to stop safely if the vehicle ahead of it suddenly applies the brakes. This is similar to the way people should drive on a highway and buses routinely operate with this strategy. Safe Follower control is much safer with maglev than with buses or rail vehicles because magnetic braking does not depend upon mechanical friction and the controller is on the guideway, knows the precise position of all vehicles, and does not depend upon communication with the vehicles. For Safe Follower control the minimum vehicle spacing could be just a few seconds, but then the block size would have to be very small. In order to achieve high capacity five second headway is a good choice, but for ODU where capacity is not critical we anticipate operating with eight second headway.

Many transit systems operate with Brick Wall criteria, meaning that a vehicle or train must be able to stop safely if the vehicle or train ahead hits a brick wall. For *M3* the maximum braking rate is 3.6 m/s^2 , the value specified in Table 1. This is achieved by a combination of maximum magnetic braking and some mechanical braking. This fast braking could cause some injuries and would be rarely used, but is preferable to hitting another train or large object.

With eight second headway and a deceleration rate of 3.6 m/s^2 the maximum allowable speed for a Brick Wall control is $v = 2ah = 57.6 \text{ m/s} = 113 \text{ mph}$. Thus a choice of 8 second headway for *M3* meets the Brick Wall criteria for speeds considered in this paper if we use emergency braking.

4.6 Operating strategy

The present *M3* development is focused on working with Old Dominion University to construct and test an *M3* system on an existing guideway on the ODU campus in Norfolk, Virginia. The original design envisioned a single vehicle that could carry up to 100 passengers at speeds up to 40 mph on a 990 meter long guideway with a stop at each end and one in the middle. The vehicle would have made a round trip in seven minutes while stopping at all stations. An important part of the project is for ODU to conduct a ridership study to see how the *M3* system might be operated so as to be of maximum benefit to the University. In this section we consider possible modes of operation that can serve as input to the ODU studies.

For the *M3* design we choose to use two smaller vehicles with higher acceleration and maximum speed than the single vehicle originally planned. In order to simplify the discussion, assume that each of the two vehicles travels exactly one km with a stop at a mid-station. With a top speed of 25 m/s (56 mph , 90 km/h) the travel time is 38 second for 0.5 km and 58 seconds for one km. The baseline 36 passenger vehicle has two wide doors on one side so as to expedite loading and unloading so that stops take an average of 20 seconds.

There are many possible strategies of operation and by choosing the one that best matches the load we can achieve much higher performance with two smaller vehicles than is possible with a single large vehicle. Two of the following strategies do not service all station-pairs but all pairs are possible if passengers take two trips or if strategies alternate, such as Asymmetric and Station Skipping.

1. Virtual train: The vehicles operate as a virtual train, going back and forth while stopping at all stations. In most cases this is not the best strategy.
2. Asymmetric: Same as the Virtual Train except that the second vehicle returns from the mid station and makes a second half-length trip. This mode is good when most of the traffic is between one end and the middle.
3. Station skipping: One vehicle goes from one end to the other and back while the other vehicle goes

from one end to the middle and back. There is no direct service from the mid station to one end.

4. Double-shuttle: One vehicle goes back and forth between one end and the mid-station and the other vehicle services the other end in the same way. This is very effective when few people are making the long trip.
5. Off-peak: One vehicle is parked and the other vehicle services all stations. The service would respond to demand, similar to an elevator.

Performance metrics are summarized in Table 4 for an assumed minimum headway of eight seconds. The travel time is for the vehicle that limits cycle time. The best metric for comparing capacity is passenger-km per hour per direction.

Table 4. Times and capacities for different strategies.

Parameter \ Mode	1	2	3	4	5
pas-km/cycle/dir	72	72	54	36	36
travel-time/cycle, s	152	152	116	76	152
station-time/cycle, s	80	80	40	40	80
headway-wait-time/cycle, s	16	16	0	0	0
cycle time, s	248	248	156	116	232
pas-km/h/dir	1045	1045	1246	1117	559

The theoretical capacities of the first four strategies are all substantially greater than the 857 pas-km/h/dir capacity of the single 100-passenger vehicle design. The actual capacity is lower than this because the vehicle schedule does not match the demand, but with diverse control strategies there can be a better match.

A good starting point in developing operating modes is to study the Morgantown People Mover (MPM) [5] that has been working successfully at the West Virginia University in Morgantown, WV for more than 30 years. This system is sometimes dubbed Group Rapid Transit because it is designed to serve a relatively small group of riders in contrast with mass transit. With GRT the vehicles can reverse direction at all stations and can skip stations in order to provide faster transportation with fewer stops. Currently MPM uses a control strategy with three modes:

- Schedule: At certain times of day the demand is high and predictable so the vehicle travel pattern is preprogrammed to optimize usage at that time. This is similar to the way commuter rail systems operate.
- Demand: When the demand is not too high the riders indicate where they want to go and the system takes them there in the shortest possible time but with some effort to have a vehicle carry multiple riders who are going to the same

location. This is similar to the way some modern elevators work with the riders specifying the floor they want to go to before they board the elevator but the elevator waiting long enough to allow more riders before starting.

- Circulation: During off-peak times an appropriate number of vehicles circulate around the loop picking up and discharging passengers that request a trip. This is similar to the way most bus systems operate.

The ODU system could use these same three modes with combinations of the described strategies used for each mode. Faculty and staff at ODU will be modeling potential traffic flow in order to see how best to meet demand.

4.7 Extension of ODU to a one-way loop

For a campus a single, short guideway may be useful, but a one way loop has substantial advantages. If the ODU guideway were extended into a loop circling the inner campus it would connect parking garages, classrooms, athletic facilities and offices thereby providing substantial time saving for people and reducing automobile traffic on campus.

The ODU campus is amenable to a rectangular loop about 0.5 km wide and one km long with short radius turns at the corners and a total of six stations. Vehicles could circle the three km guideway, including stopping at all stations, in less than six minutes. With six vehicles the average vehicle spacing would be less than 60 seconds and the capacity would be more than 2,000 pphpd or 6,000 pas-km/hr.

When peak capacity is required the vehicles could operate in a station skipping mode. For example, assume that at times of peak traffic there are two heavily used stations and four less used stations. Each vehicle can be programmed to stop at both heavily used stations but only two of the four lightly used stations. With six vehicles we can service all six pairs of the four stations so it is always possible to go from any station to any other station but the vehicles only need to make four stops instead of six stops per loop. This both increases capacity and decreases energy consumption.

4.8 Cost

Cost depends on many parameters, some of which are application specific. One of the objectives of the ODU Project is to demonstrate that the cost saving features in the design really do lead to a reduced

system cost. Table 5 gives a rough estimate of what the cost would be for building an ODU-like single guideway system that is at least one km long. It is based on the actual cost of components for the prototype test system and estimates of the cost of vehicles and other items. Based on these estimates, we believe that an ODU-like system could be built for about \$9 million per km or \$14 million per mile. A dual guideway system would cost a little less than twice this value and a system with many curves would cost a little more. This estimate does not include land acquisition, site preparation, stations or utility interconnections. An important fact is the dominance of the cost of guideways, stators and vehicles. We can afford to use more electronics if it helps reduce the cost of these items.

Table 5. Cost estimate for an ODU-like system.

Parameter	M\$/km	M\$/mi	%
Guideway; girders, piers and ties	2.50	4.02	29
Stators; 2 m per m	1.25	2.01	14
Vehicles, 2 per km	1.00	1.61	12
Inverters; 4 per 108 m	0.22	0.36	3
Sub-block switches; 2 per 12 m	0.10	0.16	1
Other components; estimated	0.30	0.48	3
Installation and initial testing; 40%	2.15	3.46	25
Contingency; 15%	1.13	1.82	13
Total	8.65	13.92	100

For comparison, a 2007 study on “Viability of Personal Rapid Transit in New Jersey” [6] gave the capacity and cost estimates shown in Table 6. We expect *M3* to have about the same cost as PRT but with higher capacity, higher maximum speed, lower specific energy consumption, and lower operating cost. As compared with any rail or PRT system the cost is expected to be substantially less.

Table 6. Capacity and cost estimates for different transit modes.

Mode	Capacity 1000 pphpd		Cost M\$/mile		
	Theory	Expected	Low	Average	High
M3, Two way	12-18	8-12		25-40	
Heavy rail	6-90	6-50	110	175-200	2000
Light rail	2-20	1-10	25	50-70	195
APM – Urban			30	100-120	145
APM – Airport			50	100-150	237
BRT Busway	0.5-16	1-11	7	14-25	50
PRT One way	3.6-43	1-9	15	20-35	50
PRT Two Way	3.6-43	1-9	25	30-50	75

BRT is Bus Rapid Transit, or buses operating on a mostly dedicated guideway.

5 OTHER LOW SPEED APPLICATIONS OF *M3*

We believe that the basic design of the *M3* system is suitable for a wide range of speeds and this is

discussed in more detail in [2]. For this paper we focus on lower speed applications with a maximum speed of about 30 m/s (67 mph, 108 km/h). While this speed is high by some transit standards, outside of the U.S. the major maglev developments are for high or very high speeds. This is partly because the earliest maglev development was focused on trying to achieve higher speeds than was possible with High Speed Rail. The first coordinated U.S. maglev development was the National Maglev Initiative launched by the Federal Railroad Administration in 1975 with principal support from Senator Patrick Moynihan. This effort was focused on developing a system with a maximum speed of 300 mph (134 m/s, 483 km/h) and led to some creative designs [9] but no construction of working models.

The world’s first operating maglev system was a low speed 600 meter shuttle in Birmingham, England, a system that worked reliably for many years but has been replaced by a cable propelled APM. The Japanese HSST system and the newer Korean maglev design are for lower speed applications, but are reminiscent of light rail and do not take advantage of the full potential for maglev. The ODU Project could lead to creative applications of maglev for lower speeds.

5.1 Automated People Mover

APMs are the transit system of choice for most airports because the industry for building them has been fully developed and they have been proven to work well in a demanding environment. The principal problem with most APMs is their high cost and low average speeds, factors that are less important to airport designers but the principal reason that there have been very few applications in the urban market. We believe *M3* could be a direct replacement at lower cost when the design has been thoroughly proven in less demanding applications.

5.2 Rail transit

M3 could be applied as an alternative to heavy rail, light rail, and commuter rail. In order to apply *M3* for these applications we must be able to deliver a capacity of at least 12,000 pphpd as specified by the Urban Maglev Project. To do this with small vehicles we need to be able to replace the long trains currently used by heavy rail with clusters of vehicles, which is essentially a train except that there is no mechanical coupling between vehicles. These clusters act like a train and operate with Brick Wall headways that ensure one cluster can stop if the cluster in front stops instantly. With *M3* we can have a cluster of six

vehicles every 60 seconds for a capacity in excess of 12,000 pphpd or, by increasing vehicle size, capacities of at least 18,000 pphpd. With five second intra-cluster headway there is time for one cluster to stop at a station and then move on before the next cluster arrives. For competing with heavy rail in very high capacity situations the best approach is *M3* with both express and local tracks. The express vehicles could operate at speeds up to 50 m/s for trips of 10 to 20 km while the local vehicles operate at speeds up to 25 m/s for trips of one to two km.

The *M3* alternative allows elevated guideways with much lighter girders, higher acceleration rates, reduced energy consumption, accurate position sensing, and reduced manpower requirements. An *M3* System can be used as a replacement for rail transit in new applications or to replace existing installations with an eye on reducing cost.

5.3 Alternative to Personal Rapid Transit

Developers of Personal Rapid Transit envision three to four passenger vehicles operating on demand to move passengers from source to destination without intermediate stops. The first major installation of a PRT system is an Ultra system [10] now under construction at Heathrow Airport near London England. The initial installation, scheduled for operation in 2009, uses 4-passenger, battery-powered vehicles running on a dual guideway 3.8 km (2.4 miles) long to connect one terminal to a parking lot. There are 78 vehicles that travel at speeds up to 40 km/s (25 mph). Other PRT designs that are in an advanced state of development include Vectus, Skyweb Express, and Cabintaxi KK3. These designs use Linear Induction Motor propulsion with higher speed and acceleration than Ultra.

For reasonable capacity, PRT requires off-line loading and unloading and short headway between vehicles traveling on the main guideway. This, in turn, requires fast acting switches for directing vehicles into and out of stations. For safe travel a vehicle must always be able to stop before reaching a switch if the switch is in motion. If the switch has mechanical components on the guideway then short headway is not possible. PRT systems solve this problem by having the movable switch components on the vehicle. *M3* vehicles can be switched in a variety of ways that are in commercial use today, but because of the wrap-around nature of the suspension these switches all require mechanical motion of guideway components. The switches are useful for moving vehicles into and out of storage or maintenance areas but not for frequent use by operating vehicles. Although *M3* cannot operate in

the classic PRT mode we can ask the question: Is *M3* a viable alternative to PRT for some applications? The answer is yes.

An explanation of how *M3* can serve a PRT like function can be found by studying the example of the MPM at West Virginia University. This system has many features of a PRT except that the vehicles hold eight people seated and 12 standing, a design sometimes referred to as Group Rapid Transit. The electrically propelled vehicles operate at an average speed of 14 mph and a maximum speed of 30 mph on a dual guideway that is 5.8 km (3.6 miles) long with stations at each end and three intermediate locations. Vehicles can reverse direction at any station with a potential for nonstop travel between any station pair. The original vehicles have carried more than 30,000 people per day and have a peak capacity of 1,500 pphpd.

The advantage of MPM is the large reduction in automobile traffic and the resulting reduction in congestion and parking problems. UWV is a community of 36,000 students and staff with a long campus strung out along the Monongahela River, so a transit system like this is a major asset. A lot of thought has gone into the development of the guideway, stations, vehicles, and control system. The system is well maintained with continuing improvements and has operated with outstanding safety for 33 years. A study in 2006 found that in 30 years "Morgantown had completed over 110 million serious-injury free passenger miles" and was more than an order of magnitude safer than surface transportation modes at a similar university in the Midwest. Anyone contemplating constructing a PRT would do well to study MPM and its operation.

The primary disadvantage of MPM is cost. The initial cost, including development, was \$126 million (\$350 million in 2008 dollars), funded in large part by a Federal Grant. The annual operating cost is \$3 million, about \$2 per vehicle mile, with a staff of 48 required for maintenance and surveillance.

Reasons for the high capital and operating cost: there are 71 vehicles that accumulate more than 1.5 million miles of travel per year so they need to be continually rebuilt; the middle stations are large and expensive with more than 600 meters (2,000') of deceleration and acceleration lanes per station and a complex arrangement of switches and loading areas; the guideway has to be heated in the winter to prevent wheel slippage; and the stations have potential safety problems so they require continuous remote monitoring by a sizable staff.

If this system were replaced by a PRT system with small wheel-suspended passenger vehicles, these maintenance problems could become worse. For a

system this size the advantages of off-line loading are illusory so an *M3* system without off-line loading is a viable alternative. Modern PRT designs are less expensive but have many of the same problems as MPM with vehicle maintenance, station complexity and empty vehicle management. There is not yet convincing proof that small vehicle PRT could provide the peak capacity of MPM at lower cost.

A number of other universities with large campuses have expressed strong interest in installing a PRT-like system in order to connect campus buildings and deal with severe traffic congestion and parking problems, but cost has always been a deterrent.

We can replace the MPM guideway with a dual *M3* guideway with a short radius turn at each end. The stations can be very simple: locate two elevators at each station and use the elevators to move passengers up to the guideway level and meet the vehicles that stop. With a maximum speed of 25 m/s and an average speed, including stops, of 12 m/s, the vehicles can make an 11.6 km (7.2 mile) round trip in 16 minutes. As compared with MPM, the end-to-end travel time is reduced from 11.5 minutes to 7.5 minutes. With 24 vehicles there is a vehicle every 40 seconds for a capacity of 3,240 pphpd, twice the capacity of MPM. At peak hours the vehicles can use station skipping to increase capacity between two stations where 80% of the traffic is known to occur.

The *M3* alternative to PRT is viable for any campus where total distances are not too large. A maglev system can be expected to reduce maintenance and energy consumption, a major reduction in the number of vehicles and staff for maintenance and surveillance, land area for stations, travel time and, most important, cost. For still larger campuses two or more loops can be used with passenger, rather than vehicles, transferring between loops. With station wait times less than a minute this transfer should be acceptable and avoids a lot of vehicle switching complexity.

6 CONCLUSIONS

The U.S. Urban Maglev Project was based on the correct assumption that a well designed maglev system can offer superior performance at equal or lower cost as compared with all conventional guideway-based urban transit systems. The *M3* urban maglev was developed as part of this Project and is based on four key features:

- Permanent magnets for ElectroMagnetic Suspension and guidance
- Small vehicles and lightweight guideways

- High efficiency LSM propulsion with guideway based control
- Focus on safety and reliability

The design will soon be tested on an ODU guideway for speeds up to 25 m/. The same basic design can be applied to a range of applications. Preliminary performance and cost data for the ODU project indicates that the *M3* design leads to a lower cost and higher performance than any competing transit system using dedicated guideways.

7 ACKNOWLEDGMENTS

The authors would like to acknowledge the support of the Federal Transit Administration. Many MagneMotion staff has contributed, particularly Mike Bottasso, Jason Young, Jesse Mendenhall, and Todd Webber. As the project progresses we expect there to be important contributions by faculty and students at ODU. This work builds on the substantial development done by the German and Japanese maglev developers, and by MIT and other U.S. groups that contributed to the National Maglev Initiative, which owed its origin to the vision of U.S. Senator Patrick Moynihan.

8 REFERENCES

The internet is an excellent source of information about all forms of innovative transportation and most of the important sites can be found through standard searches or from links at

<http://faculty.washington.edu/jbs/itrans/>,

a site dedicated to information on this topic.

1. www.fta.dot.gov/documents/Proceedings/FTA_Maglev_Workshop_Sept2005
2. IEEE Special Issue on *Linear Motor Powered Transportation: Past, Present and Future*, to be published in April, 2009.
3. *Transportation Energy Data Book* (Edition 27, 2008), published by Oak Ridge national Laboratory, available at <http://cta.ornl.gov/data/index>.
4. Sklar, et al, "Safe-Approach" *Vehicle-Follower Control*, IEEE Transactions on Vehicular Technology, Vol. VT-28, No. 1, Feb. 1979.
5. http://www.cities21.org/morgantown_TRB_111504.pdf
6. <http://faculty.washington.edu/jbs/itrans/big/PRTfinalreport.pdf>
7. <http://ntl.bts.gov/DOCS/TNM.html>
8. Foster Miller web site, *Advanced Linear Motor*.
9. FTA, *Urban Maglev System Requirements*, Jan. 2004
10. <http://www.atsltd.co.uk/>
11. Vibhuti, Anupam, System Selection Methodology & Pphpd as an 'Incomplete' Unit of Comparison for Public Transit Systems, *BPRCM 2008*